

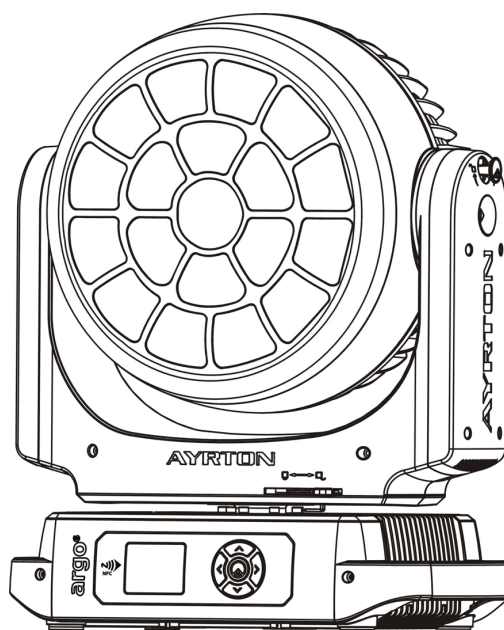

AYRTON
Digital Lighting



argo⁶
FX

User Manual



SCAN FOR
SUPPORT

CONTENTS







1. SAFETY INSTRUCTIONS	1
2. FEATURES	3
3. FIXTURE OVERVIEW	3
4. DRAWINGS	4
5. INSTALLATION INSTRUCTIONS	4
6. DMX-512 CONTROL CONNECTION	6
7. DMX-512 CONNECTION WITH DMX TERMINATOR	6
8. DEVICE DMX START ADDRESS SELECTION	7
9. OPERATING INSTRUCTIONS OF THE INTERNAL DMX WIRELESS SYSTEM	7
10. DISPLAY	8
11. NFC	27
12. DMX PROTOCOL	31
13. ERROR MESSAGES	36
14. CLEANING AND MAINTENANCE	37

1. SAFETY INSTRUCTIONS

1.1. IMPORTANT SAFETY WARNINGS

This device has left the factory in perfect condition. In order to maintain this condition and to ensure safe operation, it is absolutely necessary for the user to follow the safety instructions and warning notes written in this user manual.

In order to install, operate and maintain the lighting fixture safely and correctly we suggest that the installation and operation be carried out by qualified technicians and these instructions be carefully followed.

	<p style="text-align: center;">CAUTION!</p> <p>HIGH VOLTAGE. RISK OF SEVERE OR FATAL ELECTRIC SHOCK.</p>
	<p style="text-align: center;">CAUTION!</p> <p>ALWAYS DISCONNECT MAINS SUPPLY BEFORE REMOVING ANY FIXTURE COVERS.</p>
	<p style="text-align: center;">CAUTION!</p> <p>NEVER LOOK DIRECTLY INTO THE LIGHT SOURCE. SENSITIVE PERSONS MAY SUFFER AN EPILEPTIC SHOCK.</p>
	<p style="text-align: center;">CAUTION!</p> <p>BLUE LIGHT HAZARD : RISK GROUP 2.</p>
	<p style="text-align: center;">CAUTION!</p> <p>NEVER TOUCH THE DEVICE DURING OPERATION. COVERS MAY BE HOT</p>
	<p style="text-align: center;">CAUTION!</p> <p>DO NOT USE THE FIXTURE IN A CORROSIVE ENVIRONMENT WITH SALT WATER / SEA WATER FOR LONG TIME! AFTER USE IN CONTACT WITH SALT WATER / SEA WATER, PLEASE MAKE SURE THE FIXTURE IS CLEANED WITH FRESH WATER AND DRIED BEFORE STORAGE! FIXTURE EXPOSED TO SALT WATER / SEA WATER SHOULD NOT BE STORED IN ITS FOAM INSERT WITHOUT BEING CLEANED WITH FRESH WATER AND BEING DRIED FIRST.</p>
	<p style="text-align: center;">CAUTION!</p> <p>WARNING: CHANGES OR MODIFICATIONS TO THIS UNIT NOT EXPRESSLY APPROVED BY THE PARTY RESPONSIBLE FOR COMPLIANCE COULD VOID THE USER'S AUTHORITY TO OPERATE THE EQUIPMENT. NOTE: THIS EQUIPMENT HAS BEEN TESTED AND FOUND TO COMPLY WITH THE LIMITS FOR A CLASS A DIGITAL DEVICE, PURSUANT TO PART 15 OF THE FCC RULES. THESE LIMITS ARE DESIGNED TO PROVIDE REASONABLE PROTECTION AGAINST HARMFUL INTERFERENCE WHEN THE EQUIPMENT IS OPERATED IN A COMMERCIAL ENVIRONMENT. THIS EQUIPMENT GENERATES, USES AND CAN RADIATE RADIO FREQUENCY ENERGY AND, IF NOT INSTALLED AND USED IN ACCORDANCE WITH THE INSTRUCTION MANUAL, MAY CAUSE HARMFUL INTERFERENCE TO RADIO COMMUNICATIONS. OPERATION OF THIS EQUIPMENT IN A RESIDENTIAL AREA IS LIKELY TO CAUSE HARMFUL INTERFERENCE IN WHICH CASE THE USER WILL BE REQUIRED TO CORRECT THE INTERFERENCE AT HIS OWN EXPENSE.</p>

IMPORTANT:

This fixture's external covers are made of magnesium alloy, care should be taken to avoid scratching the surface treatment of the covers. If it is accidentally scratched, need to repair the surface treatment and monitor regularly whether the repaired surface is corroded; if the corroded surface expands, need to replace the cover.

Damage caused by the disregard of this user manual is not subject to warranty. The dealer and manufacturer will not accept liability for any resulting defects or problems.

- If the device has been exposed to temperature changes due to environmental conditions, do not power on immediately. The resulting condensation could damage the device. Leave the device powered off until it has reached room temperature.
- Ensure the sealing rubber covers of powerCON and XLR connectors are fitted properly when the device is not in use, to avoid water ingress.
- This device falls under protection-class I. Therefore, it is essential that the device be earthed.
- If either lenses or display are damaged (damage may include cracks or gashes in the material) they must be replaced.
- Electrical connections, such as replacing the power plug, must be performed by a qualified person.
- Make sure that the available voltage is not higher than that which is stated in this manual.
- Make sure the power cord is never crushed or damaged by sharp edges. If this should be the case, replacement of the cable must be done by an authorized dealer.
- If the external flexible power cord of this device is damaged, it shall be exclusively replaced by the manufacturer or their service agent or a similar qualified person in order to avoid injury.
- When the device is not in use or before performing maintenance, always disconnect the device from the mains. Only handle the power cord from the plug. Never pull the plug out of a socket by tugging the power cord.
- When powered on for the first time, some smoke or smell may occur. This is caused by coating on metal parts when heated and is normal. If you are concerned, please contact your distributor.
- Do not focus the beam onto flammable surfaces. The minimum distance between the exiting lens of the device and the illuminated surface must be greater than 0.5 meter.

Important: Please be aware that damage caused by any modifications to the device are not subject to warranty. Keep away from children and non-professionals.

1.2. GENERAL GUIDELINES

- This device is a lighting effect for professional use on stages, in discotheques, theatres, etc. the device was designed for indoor and outdoor use.
- This fixture is only allowed to be operated within the maximum alternating current as stated in the technical specifications in section 2 of this manual.
- Handle the device with care, avoid shaking or using force when installing or maintaining the device.
- If you use the quick lock cam when rigging the device, make sure the quick lock fasteners are located in the quick lock holes correctly and securely.
- Operate the device only after having familiarized yourself with its functions. Do not permit operation by persons not qualified for operating the device. Most damage is the result of unprofessional operation.
- Please use the original packaging if the device is to be transported.
- The applicable temperature for the device is between -20°C to 45°C. Do not use the device outside of this temperature range.
- The light source contained in this luminaire shall only be replaced by the manufacturer or his service agent or a similar qualified person.

Important: For safety reasons, please be aware that all modifications to the device are forbidden. If this device is operated in any way different to the ones described in this manual, the product may suffer damage and the warranty becomes void. Furthermore, any other operation may lead to short-circuits, burns, electric shocks etc.

2. FEATURES

POWER SUPPLY:

- AC100-240V~, 50/60Hz
- Power Consumption: 950W

LIGHT SOURCE:

- LED: 19 pcs 4 in 1 RGBW LEDs
318 pcs MULTILED RGB
- Extremely long Life: >20,000H

MOVEMENT:

- Pan movement: Infinite rotation (16 bit)
- Tilt movement: Infinite rotation (16 bit)
- Advanced moving system: fast, stable and quite, auto X-Y repositioning

COLORS:

- Excellent color mixing and rainbow effect

FEATURES:

- 3 Control channel modes: 26/50/127 channels
- 2 Operation modes: DMX-512, Master / Slave mode
- Fast motorised linear zoom
- Strobe effect with 1-25 flashes per second and pulse effect
- Dimmer: 0%~100% full range dimming

DISPLAY:

- Advanced and convenient full-color LCD
- Can be changed 180° reverse to fit for different installation position

SOFTWARE:

- Upgrades: fast and convenient through DMX cable with DMX-512 controller
- Reset DMX address, reset can all be done by the DMX controller
- Running time of fixture on display for reference

OTHER SPEC:

- Input signal isolation: guarantees stable signal transmission without interference
- Advanced RDM function

WEIGHT

- Net weight: 23.2 kg

3. FIXTURE OVERVIEW

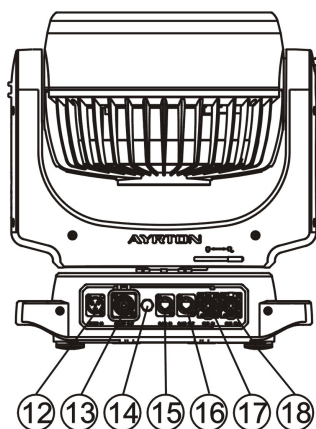
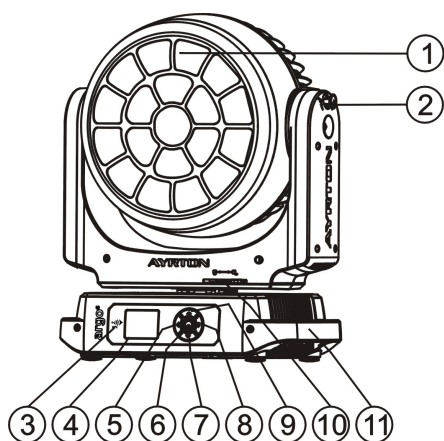

- 1) Lenses Assembly
- 2) Tilt Lock
- 3) NFC
- 4) Display
- 5) Left-button
- 6) Center-button
- 7) Down-button
- 8) Right-button
- 9) Up-button
- 10) Pan Lock
- 11) Handle
- 12) Power In
- 13) Power Out
- 14) Valve
- 15) RJ45 In
- 16) RJ45 Out
- 17) DMX In
- 18) DMX Out

4. DRAWINGS

4.1. Fixture Dimension

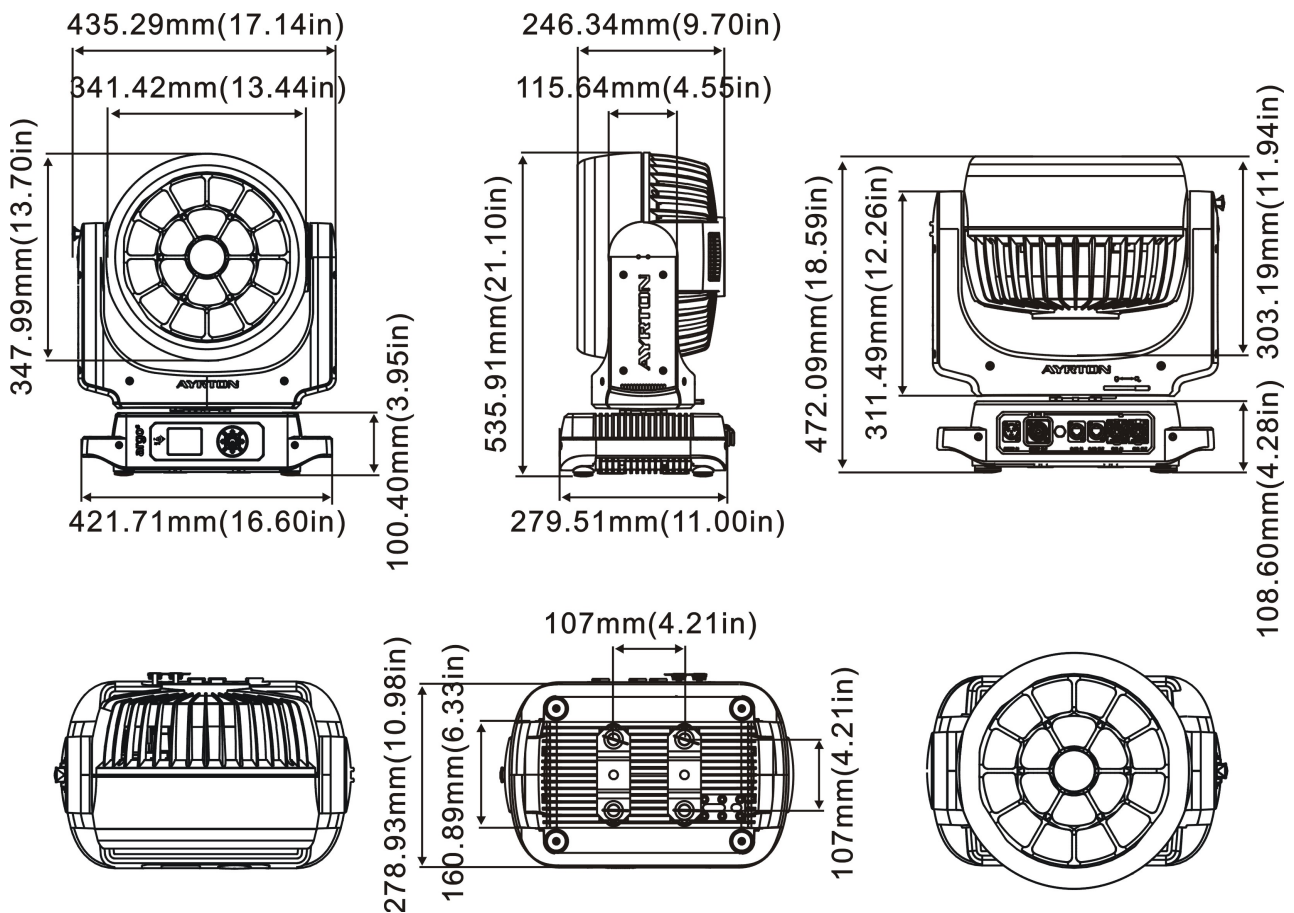

5. INSTALLATION INSTRUCTIONS

5.1. Rigging the device

	<p>CAUTION!</p> <p>PLEASE CONSIDER THE RESPECTIVE NATIONAL NORMS DURING THE INSTALLATION. THE INSTALLATION MUST ONLY BE CARRIED OUT BY A QUALIFIED PERSON.</p>
---	---

- The installation of the effect has to be built and constructed in a way that it can hold 10 times the weight for 1 hour without any harming deformation.
- The installation must always be secured with a secondary safety attachment, e.g. an appropriate safety rope.
- Never stand directly below the device when mounting, removing or servicing the fixture.
- The operator has to make sure the safety relating and machine technical installations are approved by an expert before taking the device into operation for the first time.
- These installations have to be approved by a skilled person once a year.
- Overhead mounting requires extensive experience, including amongst others calculating working load limits, installation material being used, and periodic safety inspection of all installation material and the device. If you lack these qualifications, do not attempt the installation yourself. Improper installation can result in bodily injury.

5.2. Rigging using the omega brackets

Important: This step is very important to ensure safe rigging of the fixture.

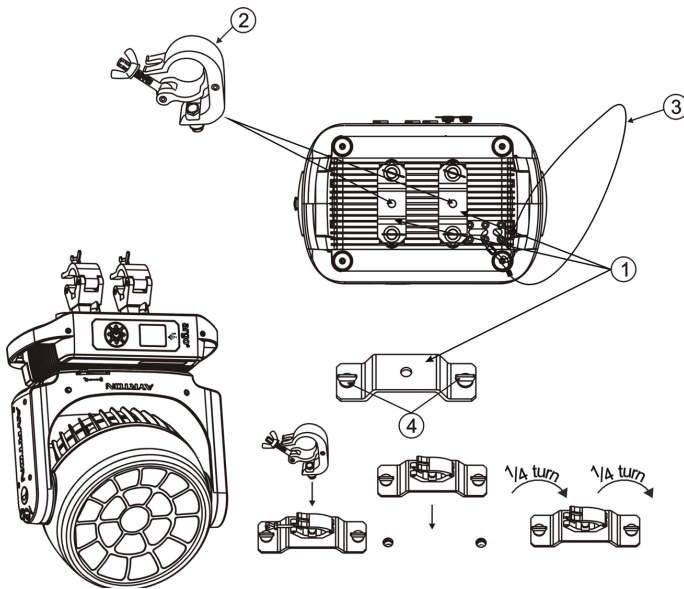

- 1) Omega bracket
- 2) Clamp
- 3) Safety rope
- 4) Quick-lock fastener

- Fix the clamp to the bracket by tightening the M12 nut and bolt to the bracket through the $\Phi 13$ hole in the middle of the bracket.
- Insert the quick-lock fasteners of the first Omega holder into the respective holes on the bottom of the device. Tighten the quick-lock fasteners fully clockwise.
- Install the second Omega holder.
- Pull the safety cable through the holes on the bottom of the base and over the trussing system or another suitable rigging point. Insert the end into the carabiner and tighten the safety screw.

5.3.RIGGING DRAWINGS

Important:

Overhead rigging requires extensive experience, including (but not limited to) calculating working load limits, specifying installation/ rigging materials, and periodic safety inspection of all installation material as well as the device. If you lack these qualifications, do not attempt the rigging of this device yourself. Improper installation/ rigging can result in serious bodily injury.

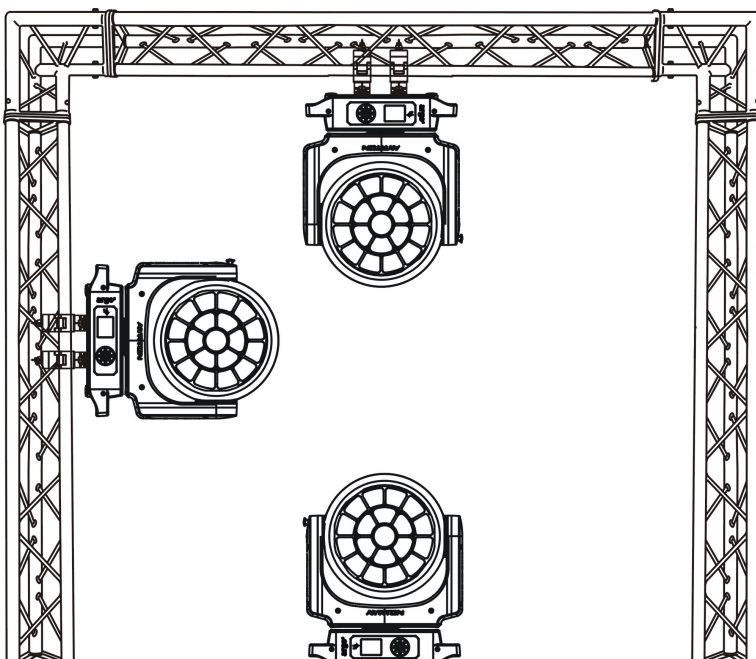

- Be sure this fixture is kept at least 0.1m away from any flammable materials (decoration etc.).
- Always use and install the supplied safety cable as a safety measure to prevent accidental damage and/or injury in the event the clamp fails.
- Rig the projector high enough to provide clearance for people who may walk beneath the beam path or establishing a restricted access area that extends beyond the beam hazard distance.

- Warnings! Please DO NOT let other external intense lights to shine through the fixture front lens, it may cause significant internal damages!
- When install fixture outdoor at day time (with power off), please make sure that the fixture front lens is NOT facing the sun.
- When use fixture outdoor at day time (with power on), please avoid fixture front lens facing the sun.
- When fixture is on standby outdoor at day time (with power on), please make sure the "sun protection" mode is ON (default).

WARNING!

After installation in a corrosive environment, the external magnesium alloy covers surface shall not be in contact with other metal items (keep at least 5mm distance from other metal items).

Do not install and use the fixture in a corrosive environment with salt water / sea water for long time! After use in contact with salt water / sea water, please make sure the fixture is cleaned with fresh water and dried before storage! Fixture exposed to salt water / sea water should not be stored in its foam insert without being cleaned with fresh water and being dried first.

6. DMX-512 CONTROL CONNECTION

Connect the provided male side of the XLR cable to the female XLR output of your controller and the female side of the XLR cable to the male XLR input of the device. You can connect multiple devices together in a serial fashion. The cable needed should be two core, screened cable with XLR input and output connectors. Please refer to the diagram below.

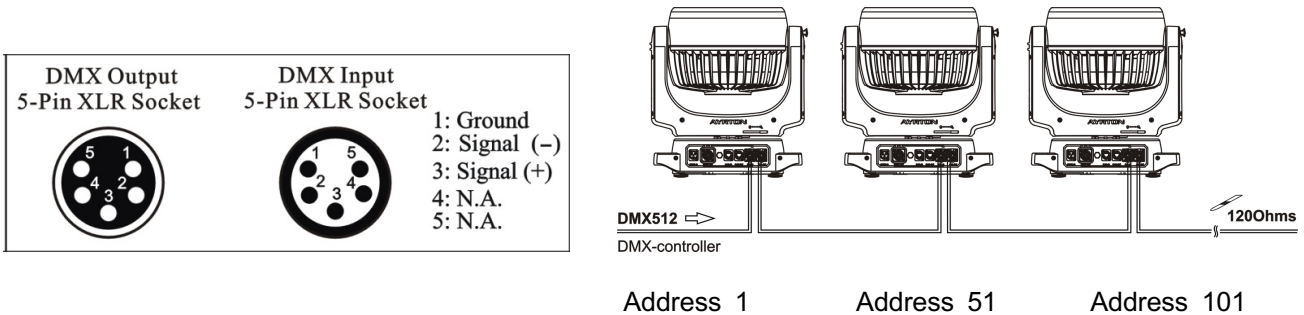

7. DMX-512 CONNECTION WITH DMX TERMINATOR

For installations where the DMX cable has to run over a long distance or is in an electrically noisy environment, such as in a discotheque, it is recommended to use a DMX terminator. This helps in preventing corruption of the digital control signal caused by electrical noise. The DMX terminator is an XLR plug with a 120 Ω resistor connected between pins 2 and 3, which is then plugged into the output (female) XLR socket of the last fixture in the chain. Please see illustrations below.

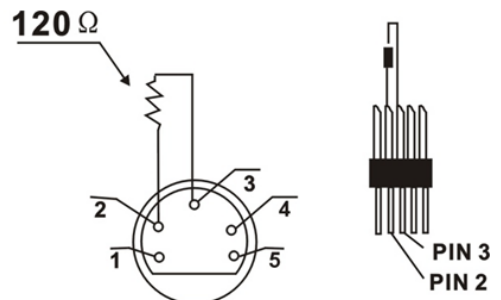

8. DEVICE DMX START ADDRESS SELECTION

All fixtures should be given a DMX starting address when using a DMX signal, so that the correct fixture responds to the correct control signals. This digital starting address is the channel number from which the fixture starts to “listen” to the digital control information sent out from the DMX controller. The allocation of this starting address is achieved by setting the correct address number on the display located on the base of the device.

You can set the same starting address for all fixtures or a group of fixtures, or set different addresses for each fixture individually.

If you set the same address on all devices, all the devices will start to “listen to” the same control signal from the same channel number. In other words, changing the settings of one channel will affect all the fixtures simultaneously.

If you set a different address, each unit will start to “listen to” the channel number you have set, based on the quantity of control channels of the unit. That means changing the settings of one channel will affect only the selected device.

In the case of the LED moving head, in 50 channel mode, you should set the starting address of the first unit to 1, the second unit to 51 ($50 + 1$), the third unit to 101 ($50 + 51$), and so on.

9. OPERATING INSTRUCTIONS OF THE INTERNAL DMX WIRELESS SYSTEM

9.1 Equipments:

DMX 512 controller, wireless transmitter, and the fixtures with wireless receiver.

9.2 Message from the LED indicator:

- 1) Rapid flashing red/Green: logging in to a transmitter.
- 2) Slow flashing Red/Green: Logged on a transmitter and the DMX line is idle (No DMX is connected to transmitter).
- 3) Solid Green: Logged on to a transmitter and receiving DMX data.
- 4) Solid Red: Not logged on to a transmitter (free).

9.3 WDMX in the menu of the fixture:

On a fixture installed with wireless system, in order to switch between wireless control system and traditional DMX control (with cable), a new menu WDMX is added to the display board.

ON: (Activate WDMX)

1) When the fixture is on power, and the WDMX is activated to ON status, but did not connect to the controller and did not log in to the transmitter, the fixture will search for the DMX signal source. If the fixture is connected to the DMX controller it can be controlled by DMX controller; if it is log in to the wireless transmitter, it can be controlled by the Transmitter.

2) When the fixture is power off, and the WDMX is in ON status, if the fixture is connected to DMX controller. After the fixture is power on, it can be controlled only by the DMX controller which connected. The fixture can log in the wireless transmitter, and receive only radio signal from transmitter, but not DMX from the transmitter.

OFF: (De-activate WDMX)

In this status, wireless system is not activated, so the fixture can not log in the transmitter.

REST: (reset WDMX memory)

Can remove the fixture from the connection with the transmitter, the fixture become free and ready to log in any transmitter.

9.4 Setup the wireless system:

- 1) Connect the transmitter with the DMX controller.
- 2) To make the fixture installed with wireless receiver log in to the transmitter.
 - a) Initially, the indicator on the receiver fixture should be in Solid red.
 - b) Press and hold the configuration button on transmitter for less than 3 seconds the red/green LEDs on the transmitter and the receiver fixture will flash rapidly for about 5~10 seconds while the system goes through its setup procedure.
 - c) Once the receiver fixture is logged in to the transmitter (T1), the fixture with wireless receiver will keep the memory, even if restart the power, this unit will log in the transmitter (T1) automatically.
- 3) Use the DMX 512 to control the fixture

9.5 Remove the receivers from transmitter (T1) and to log in to another transmitter (T2):

Case 1: Remove a receiver:

- a) On the control board of the fixture, enter menu to activated the function of REST;
- b) The LED for wireless on the fixture should turn to Solid red; the receiver can log out from the transmitter (T1);
- c) press the configuration button on transmitter (T2) for less than 3 second, then the fixture will start to connect with the transmitter (T2).

Case 2: Remove all receivers from a transmitter (T1) to log in to T2:

- a) Press and hold the configuration button on the T1 as least 5 seconds, can clear the connection with all the fixtures;
- b) All the red/green LEDs on the receiver fixtures will turn to Solid red to indicate that the receivers are unassigned and removed from the transmitter (T1);
- c) Press and hold the configuration button on the T2 less then less than 3 second, the fixtures will connect with the T2.



PS:

1. Please log the receivers out from the transmitter after every job, so that the receivers are in free un assigned state and ready to be assigned to a transmitter.
2. Do not connect the fixture which is under the communication of wireless system to the DMX controller, otherwise it will cause interference from the DMX controller.

10. DISPLAY

The Display offers several features: you can set the starting address, run the pre-programmed program or reset the device.

The main menu is accessed by double clicking  -button until the display starts flashing. Browse through the menu by pressing the  -button,  -button,  -button or  -button .

Press  for 2 seconds in order to exit menu, double click  for confirm. After accessing the edit mode, the unit will automatically exit to the main menu after 15 seconds from the last button press.

When the unit is powered on, if no data signal is connected after 1 minute, then the display will switch off automatically.

Default settings shaded

Address	Main	DMX Address: xxx Decimal Universe: xxxxx Net: xx Sub-Net: x Universe: x Signal	DMX Address Decimal Universe Net Sub-Net Universe Dmx/WDMX/Artnet/Sacn
	Effect	FollowMain DMX Address: xxx Decimal Universe: xxxxx Net: xx Sub-Net: x Universe: x Signal	ON/OFF DMX Address Decimal Universe Net Sub-Net Universe Dmx/WDMx/Artnet/Sacn
	Pwr led pix	FollowMain DMX Address:xxx Decimal Universe:xxxxx Net:xx Sub-Net:x Universe:x Signal	ON/OFF DMX Address Decimal Universe Net Sub-Net Universe Dmx/WDMx/Artnet/Sacn
	Liquid effect	Decimal Universe: xxxxx Net: xx Sub-Net: x Universe: x Signal	Decimal Universe Net Sub-Net Universe Artnet/Sacn
Mode	User Mode	Stand Mode Basic Mode Extend Mode User Mode A User Mode B User Mode C	User's mode to change channel numbers
	Edit User ModeA/B/C	Max channel PAN :	Preset User modes A,B,C :
Options	Status	No DMX Mode Sun Protection Pan Reverse Tilt Reverse Pan Degree Tilt Degree Feedback Init PAN Init TILT Pan/Tilt Spd Hibernation DMX Output	Close/Hold/Auto ON/OFF ON/OFF ON/OFF 630/540 270/540 ON/OFF ON/OFF ON/OFF Fast/Medium/Slow OFF , 01M~99M ON/OFF
			Auto run if no DMX Sun Protection Pan Reverse movement Tilt Reverse movement Pan Degree Select Tilt Degree Select Movement Feedback Init PAN Init TILT Movement Speed Stand by Mode DMX Output

	Service PIN	Service PIN RDM UID Set Ip Set Mask DHCP Cross Load SW Clr LED Timer Clr Error Info Set LED BIN	Password=XXX Xxxxxx xxx.xxx.xxx.xxx xxx.xxx.xxx.xxx ON/OFF ON/OFF ON/OFF ON/OFF C14...	Service Password"=050" RDM UID Set Ip Set Mask DHCP Cross Load SW Clr LED Timer Clr LED Timer Set LED BIN
	Fans Control	Fans Speed	Auto Stage Silence Super Silence	Fans Speed select
		Constant Fans	ON/OFF	Constant Fans
	Disp.Setting	Shutoff Time Flip Display Key Lock DispFlash	02~60m 05m ON/OFF ON/OFF ON/OFF	Display shutoff time Reverse 180 degree Key Lock DispFlash
	Temp. C/F	Celsius Farhenheit		Temperature switch between °C/°F
	Initial Pos.	PAN =XXX		Initial effect position
	Wireless DMX	Activate WDMX Rest WDMX		Activate WDMX Rest WDMX
	Dim Curve	Square Law Linear		Dim Curve
	Ip From Mac	ON/OFF		Ip From Mac
	Refresh Select	1.2K 2.4K 16K 25K		Refresh Select
	Defog	OFF/AUTO/ON		Defog
	Trigger	DMX Value Disp. Set to Slave Auto Program	PAN..... Slave 1, Slave 2, Slave 3 Master/Alone	DMX Value Disp. Set to Slave Auto Program
	ResetDefault	ON/OFF		Restore factory set.
	Reset User	Address	...the same as menu Address below	DMX address setting
		Mode	Stand Mode Basic Mode Extend Mode User Mode A User Mode B User Mode C	User's mode to change channel numbers
		Fans Speed	Auto Stage Silence	Fans Speed select

			Super Silence	
		Constant Fans	ON/OFF	Constant Fans
Info	Time Info.	Current Time Ttl Life Hrs Last Run Hrs LED Hours Timer PIN Clr Last Run		XXXX(Hours) XXXX(Hours) XXXX(Hours) XXXX(Hours) Password=XXX ON/OFF
	Temp. Info	XXX°C/°F		Temp. Info
	Humidity	x%		Humidity
	Fan Info.	xxxx RPM		Fan information
	Software Ver	V1.0.....		Software version
	Network	IP,Mask,Mac		Network
	Error Info.	Error Record 1 :		Error Info.
SN	xxxxx.....		SN	
Test	Home	All Pan&Tilt ZOOM		Reset All Reset Pan&Tilt ZOOM
	Test Channel	PAN		Test function
	Manual Ctrl.	PAN =XXX :		Fine adjustment of the lamp
	Calibration	-Password- PAN :		Password "050" Calbrate and adjust the effects to standard/right position
Preset	Select Prog.	Prog. Part 1 = Program 1 ~ 10 Prog. Part 2 = Program 1 ~ 10 Prog. Part 3 = Program 1 ~ 10	Program 1 Program 2 Program 3	Select programs to be run
	Edit Prog.	Program 1 : Program 10	Program Test Step 01=SCxxx Step 64=SCxxx	Testing program Program in loop Save and exit
	Edit Scenes	Edit Scene 001 ~ Edit Scene 250	Pan,Tilt,..... --Fade Time-- --Secne Time-- Input By Outside	Save and automatically return manual scenes edit
	Scenes Input	XX~XX		Scenes Input

10.1. Address

10.1.1. Main

With this function, you can adjust the desired DMX-address via the Display.

1. Double clicking center button to access main menu.
2. Tap the <Up/Down> button until "Address" is displayed.
3. Double clicking center button to access "Address", Tap the <Up/Down> button to select "Main".
4. Double clicking center button to access "Main" menu, The display will show "DMX Address: xxx"、"Decimal Universe: xxxxx"、"Net: xx"、"Sub-Net: x"、"Universe:

x”、 “Signal”.

5. Double click the center button to confirm or long press the center button to return to the main menu.

10.1.2. Effect

1. Double clicking center button to access main menu.
2. Tap the <Up/Down> button until “Address” is displayed.
3. Double clicking center button to access “Address”, Tap the <Up/Down> button to select “Effect”.
4. Double clicking center button to access “Effect” menu, The display will show “FollowMain”、 “DMX Address: xxx”、 “Decimal Universe: xxxxx”、 “Net: xx”、 “Sub-Net: x”、 “Universe: x”、 “Signal”.
5. Double click the center button to confirm or long press the center button to return to the main menu.

10.1.3. Pwr led pix

1. Double clicking center button to access main menu.
2. Tap the <Up/Down> button until “Address” is displayed.
3. Double clicking center button to access “Address”, Tap the <Up/Down> button to select “Pwr led pix”.
4. Double clicking center button to access “Pwr led pix” menu, The display will show “FollowMain”、 “DMX Address: xxx”、 “Decimal Universe: xxxxx”、 “Net: xx”、 “Sub-Net: x”、 “Universe: x”、 “Signal”.
5. Double click the center button to confirm or long press the center button to return to the main menu.

10.1.4. Liquid effect

1. Double clicking center button to access main menu.
2. Tap the <Up/Down> button until “Address” is displayed.
3. Double clicking center button to access “Address”, Tap the <Up/Down> button to select “Liquid effect”.
4. Double clicking center button to access “Liquid effect” menu, The display will show “Decimal Universe: xxxxx”、 “Net: xx”、 “Sub-Net: x”、 “Universe: x” 、 “Signal”.
5. Double click the center button to confirm or long press the center button to return to the main menu.

10.2. Mode

10.2.1. User Mode

With this function, you can create user defined channel orders.

1. Double clicking center button to access main menu; Tap the <Up/Down> button until “Mode” is displayed. Double clicking center button to enter.
2. Press <Up/Down>, the display will show “User Mode”.
3. Double clicking center button to enter.
4. When in “Extend Mode”, Press <Up/Down> button to select “Basic Mode”, “Stand Mode”, “Extend Mode”, “User Mode A”, “User Mode B” and “User Mode C”.
5. Double click the center button to confirm or long press the center button to return to the main menu.

10.2.2. Edit User Mode

With this function, you can adjust the rest user defined channel order.

1. Double clicking center button to access main menu; Tap the <Up/Down> button until “Mode” is displayed. Double clicking center button to enter.

2. Press <Up/Down>, the display will show "Edit User Mode".
3. Double clicking center button to enter.
4. Set up "Max Channel=xxx" and select channel value.
5. Set up "Mode B" and "Mode C" by the same way.
6. Double click the center button to confirm or long press the center button to return to the main menu.

10.3. Options

10.3.1. Status

No DMX Status

With this function, when the drive is not DMX signal, it runs automatism, close, hold and music, the default is hold.

1. Double clicking center button to access main menu.
2. Tap the <Up/Down> button until "Options" is displayed.
3. Double clicking center button to access "Options", Tap the <Up/Down> button to select "Status".
4. Double clicking center button to access "Status" menu, Tap the <Up/Down> button to select "No DMX Status".
5. Double clicking center button to access "No DMX Status", The display will show "Hold", Tap the <Up/Down> button to select "Close", "Auto".
6. Double click the center button to confirm or long press the center button to return to the main menu.

Sun Protection

1. Double clicking center button to access main menu.
2. Tap the <Up/Down> button until "Options" is displayed.
3. Double clicking center button to access "Options", Tap the <Up/Down> button to select "Status".
4. Double clicking center button to access "Status" menu, Tap the <Up/Down> button to select "Sun Protection".
5. Double clicking center button to access "Sun Protection", The display will show "OFF", Tap the <Up/Down> button to select "ON".
6. Double click the center button to confirm or long press the center button to return to the main menu.

Pan Reverse

With this function you can reverse the Pan-movement.

1. Double clicking center button to access main menu.
2. Tap the <Up/Down> button until "Options" is displayed.
3. Double clicking center button to access "Options", Tap the <Up/Down> button to select "Status".
4. Double clicking center button to access "Status" menu, Tap the <Up/Down> button to select "Pan Reverse".
5. Double clicking center button to access "Pan Reverse", The display will show "OFF", Tap the <Up/Down> button to select "NO".
6. Double click the center button to confirm or long press the center button to return to the main menu.

Tilt Reverse

With this function you can reverse the Tilt-movement.

1. Double clicking center button to access main menu.
2. Tap the <Up/Down> button until "Options" is displayed.
3. Double clicking center button to access "Options", Tap the <Up/Down> button to select

“Status”.

4. Double clicking center button to access “Status” menu, Tap the <Up/Down> button to select “Tilt Reverse”.
5. Double clicking center button to access “Tilt Reverse”, The display will show “OFF”, Tap the <Up/Down> button to select “NO”.
6. Double click the center button to confirm or long press the center button to return to the main menu.

Pan Degree

With this function, you can select pan degree for 630 or 540.

1. Double clicking center button to access main menu.
2. Tap the <Up/Down> button until “Options” is displayed.
3. Double clicking center button to access “Options”, Tap the <Up/Down> button to select “Status”.
4. Double clicking center button to access “Status” menu, Tap the <Up/Down> button to select “Pan Degree”.
5. Double clicking center button to access “Pan Degree”, The display will show “540”, Tap the <Up/Down> button to select “630”.
6. Double click the center button to confirm or long press the center button to return to the main menu.

Tilt Degree

With this function, you can select tilt degree for 270 or 540.

1. Double clicking center button to access main menu.
2. Tap the <Up/Down> button until “Options” is displayed.
3. Double clicking center button to access “Options”, Tap the <Up/Down> button to select “Status”.
4. Double clicking center button to access “Status” menu, Tap the <Up/Down> button to select “Tilt Degree”.
5. Double clicking center button to access “Tilt Degree”, The display will show “540”, Tap the <Up/Down> button to select “270”.
6. Double click the center button to confirm or long press the center button to return to the main menu.

Feedback

With this function, you can feedback switch of pan movement or tilt movement.

1. Double clicking center button to access main menu.
2. Tap the <Up/Down> button until “Options” is displayed.
3. Double clicking center button to access “Options”, Tap the <Up/Down> button to select “Status”.
4. Double clicking center button to access “Status” menu, Tap the <Up/Down> button to select “Feedback”.
5. Double clicking center button to access “Feedback”, The display will show “ON”, Tap the <Up/Down> button to select “OFF”.
6. Double click the center button to confirm or long press the center button to return to the main menu.

Init PAN

With this function, you can feedback switch of pan movement or tilt movement.

1. Double clicking center button to access main menu.
2. Tap the <Up/Down> button until “Options” is displayed.
3. Double clicking center button to access “Options”, Tap the <Up/Down> button to select “Status”.
4. Double clicking center button to access “Status” menu, Tap the <Up/Down> button to

select "Init PAN".

5. Double clicking center button to access "Init PAN", The display will show "ON", Tap the <Up/Down> button to select "OFF".
6. Double click the center button to confirm or long press the center button to return to the main menu.

Init TILT

With this function, you can feedback switch of pan movement or tilt movement.

1. Double clicking center button to access main menu.
2. Tap the <Up/Down> button until "Options" is displayed.
3. Double clicking center button to access "Options", Tap the <Up/Down> button to select "Status".
4. Double clicking center button to access "Status" menu, Tap the <Up/Down> button to select "Init TILT".
5. Double clicking center button to access "Init TILT", The display will show "ON", Tap the <Up/Down> button to select "OFF".
6. Double click the center button to confirm or long press the center button to return to the main menu.

Pan/Tilt Spd

With this function, you can select scan mode from 1 to 4.

1. Double clicking center button to access main menu.
2. Tap the <Up/Down> button until "Options" is displayed.
3. Double clicking center button to access "Options", Tap the <Up/Down> button to select "Status".
4. Double clicking center button to access "Status" menu, Tap the <Up/Down> button to select "Pan/Tilt Spd".
5. Double clicking center button to access "Pan/Tilt Spd", The display will show "Fast", Tap the <Up/Down> button to select "Fast", "Medium", "Slow".
6. Double click the center button to confirm or long press the center button to return to the main menu.

Hibernation

The device and step motors will be power off if the fixture stay without DMX signal for 15 mins (Factory default).And the fixture will be reset before working once it receive DMX signal again.

1. Double clicking center button to access main menu.
2. Tap the <Up/Down> button until "Options" is displayed.
3. Double clicking center button to access "Options", Tap the <Up/Down> button to select "Status".
4. Double clicking center button to access "Status" menu, Tap the <Up/Down> button to select "Hibernation".
5. Double clicking center button to access "Hibernation", The display will show "OFF", Tap the <Up/Down> button to select "01M", "02M" . . . "99M".
6. Double click the center button to confirm or long press the center button to return to the main menu.

DMX Output

1. Double clicking center button to access main menu.
2. Tap the <Up/Down> button until "Options" is displayed.
3. Double clicking center button to access "Options", Tap the <Up/Down> button to select "Status".
4. Double clicking center button to access "Status" menu, Tap the <Up/Down> button to select "DMX Output".

5. Double clicking center button to access “DMX Output”, The display will show “OFF”, Tap the <Up/Down> button to select “ON”.
6. Double click the center button to confirm or long press the center button to return to the main menu.

10.3.2. Service PIN

Password

The Password for this function is “050”.

RDM UID

1. Double clicking center button to access main menu.
2. Tap the <Up/Down> button until “Options” is displayed.
3. Double clicking center button to access “Options”, Tap the <Up/Down> button to select “Service PIN”.
4. Double clicking center button to access “Service PIN” menu, Tap the <Up/Down> button to select “RDM UID”.
5. Double clicking center button to access “RDM UID”, The display will show “XXXXXX”.
6. Double click the center button to confirm or long press the center button to return to the main menu.

Set IP

1. Double clicking center button to access main menu.
2. Tap the <Up/Down> button until “Options” is displayed.
3. Double clicking center button to access “Options”, Tap the <Up/Down> button to select “Service PIN”.
4. Double clicking center button to access “Service PIN” menu, Tap the <Up/Down> button to select “Set IP”.
5. Double clicking center button to access “Set IP”, The display will show “XXX.XXX.XXX.XXX”.
6. Double click the center button to confirm or long press the center button to return to the main menu.

Set Mask IP

1. Double clicking center button to access main menu.
2. Tap the <Up/Down> button until “Options” is displayed.
3. Double clicking center button to access “Options”, Tap the <Up/Down> button to select “Service PIN”.
4. Double clicking center button to access “Service PIN” menu, Tap the <Up/Down> button to select “Set Mask IP”.
5. Double clicking center button to access “Set Mask IP”, The display will show “XXX.XXX.XXX.XXX”.
6. Double click the center button to confirm or long press the center button to return to the main menu.

DHCP

1. Double clicking center button to access main menu.
2. Tap the <Up/Down> button until “Options” is displayed.
3. Double clicking center button to access “Options”, Tap the <Up/Down> button to select “Service PIN”.
4. Double clicking center button to access “Service PIN” menu, Tap the <Up/Down> button to select “DHCP”.
5. Double clicking center button to access “DHCP”, The display will show “OFF”, Tap the <Up/Down> button to select “ON”.
6. Double click the center button to confirm or long press the center button to return to

the main menu.

Cross Load SW

1. Double clicking center button to access main menu.
2. Tap the <Up/Down> button until “Options” is displayed.
3. Double clicking center button to access “Options”, Tap the <Up/Down> button to select “Service PIN”.
4. Double clicking center button to access “Service PIN” menu, Tap the <Up/Down> button to select “Cross Load SW”.
5. Double clicking center button to access “Cross Load SW”, The display will show “OFF”, Tap the <Up/Down> button to select “ON”.
6. Double click the center button to confirm or long press the center button to return to the main menu.

Clr LED Timer

1. Double clicking center button to access main menu.
2. Tap the <Up/Down> button until “Options” is displayed.
3. Double clicking center button to access “Options”, Tap the <Up/Down> button to select “Service PIN”.
4. Double clicking center button to access “Service PIN” menu, Tap the <Up/Down> button to select “Clr LED Timer”.
5. Double clicking center button to access “Clr LED Timer”, The display will show “OFF”, Tap the <Up/Down> button to select “ON”.
6. Double click the center button to confirm or long press the center button to return to the main menu.

Clr Error Info

1. Double clicking center button to access main menu.
2. Tap the <Up/Down> button until “Options” is displayed.
3. Double clicking center button to access “Options”, Tap the <Up/Down> button to select “Service PIN”.
4. Double clicking center button to access “Service PIN” menu, Tap the <Up/Down> button to select “Clr Error Info”.
5. Double clicking center button to access “Clr Error Info”, The display will show “OFF”, Tap the <Up/Down> button to select “ON”.
6. Double click the center button to confirm or long press the center button to return to the main menu.

Set LED BIN

1. Double clicking center button to access main menu.
2. Tap the <Up/Down> button until “Options” is displayed.
3. Double clicking center button to access “Options”, Tap the <Up/Down> button to select “Service PIN”.
4. Double clicking center button to access “Service PIN” menu, Tap the <Up/Down> button to select “Set LED BIN”.
5. Double clicking center button to access “Set LED BIN”, The display will show “C14”, “...”.
6. Double click the center button to confirm or long press the center button to return to the main menu.

10.3.3. Fans Control

Fans Speed

With this function you can set the speed of the running fans. The selections have Auto、Stage、Silence and Super Silence.

1. Double clicking center button to access main menu.
2. Tap the <Up/Down> button until “Options” is displayed.
3. Double clicking center button to access “Options”, Tap the <Up/Down> button to select “Fans Control”.
4. Double clicking center button to access “Fans Control” menu, Tap the <Up/Down> button to select “Fans Speed”.
5. Double clicking center button to access “Fans Speed”, The display will show “Auto”, Tap the <Up/Down> button to select “Stage”, “Silence”, “Super Silence”.
6. Double click the center button to confirm or long press the center button to return to the main menu.

Constant Fans

1. Double clicking center button to access main menu.
2. Tap the <Up/Down> button until “Options” is displayed.
3. Double clicking center button to access “Options”, Tap the <Up/Down> button to select “Fans Control”.
4. Double clicking center button to access “Fans Control” menu, Tap the <Up/Down> button to select “Constant Fans”.
5. Double clicking center button to access “Constant Fans”, The display will show “OFF”, Tap the <Up/Down> button to select “ON”.
6. Double click the center button to confirm or long press the center button to return to the main menu.

10.3.4. Disp. Setting

Shut off Time

With this function you can shut off the LCD display after 2 to 60 minutes. The default is 5 minutes.

1. Double clicking center button to access main menu.
2. Tap the <Up/Down> button until “Options” is displayed.
3. Double clicking center button to access “Options”, Tap the <Up/Down> button to select “Display Setting”.
4. Double clicking center button to access “Display Setting” menu, Tap the <Up/Down> button to select “Shut off Time”.
5. Double clicking center button to access “Shut off Time”, The display will show “05m”, Tap the <Up/Down> button to select “02~60m”.
6. Double click the center button to confirm or long press the center button to return to the main menu.

Flip Display

With this function you can rotate the display by 180°.

1. Double clicking center button to access main menu.
2. Tap the <Up/Down> button until “Options” is displayed.
3. Double clicking center button to access “Options”, Tap the <Up/Down> button to select “Display Setting”.
4. Double clicking center button to access “Display Setting” menu, Tap the <Up/Down> button to select “Flip Display”.
5. Double clicking center button to access “Flip Display”, The display will show “OFF”, Tap the <Up/Down> button to select “ON”.
6. Double click the center button to confirm or long press the center button to return to the main menu.

Key Lock

With this function you can activate the automatic key lock function. If this function is

activated, the keys will be locked automatically after exiting the edit mode for 15 seconds. Keeping press the <MODE/ESC> key for 3 seconds if you do not need this function.

1. Double clicking center button to access main menu.
2. Tap the <Up/Down> button until "Options" is displayed.
3. Double clicking center button to access "Options", Tap the <Up/Down> button to select "Display Setting".
4. Double clicking center button to access "Display Setting" menu, Tap the <Up/Down> button to select "Key Lock".
5. Double clicking center button to access "Key Lock", The display will show "OFF", Tap the <Up/Down> button to select "ON".
6. Double click the center button to confirm or long press the center button to return to the main menu.

DispFlash

With this function you can the entire display to be flipped by 180° to allow for better view when the fixture is hung from truss or a ceiling. This function is disabled as default.

1. Double clicking center button to access main menu.
2. Tap the <Up/Down> button until "Options" is displayed.
3. Double clicking center button to access "Options", Tap the <Up/Down> button to select "Display Setting".
4. Double clicking center button to access "Display Setting" menu, Tap the <Up/Down> button to select "DispFlash".
5. Double clicking center button to access "DispFlash", The display will show "OFF", Tap the <Up/Down> button to select "ON".
6. Double click the center button to confirm or long press the center button to return to the main menu.

10.3.5. Temperature C/F

With this function you can display the temperature in Celsius or Fahrenheit.

1. Double clicking center button to access main menu.
2. Tap the <Up/Down> button until "Options" is displayed.
3. Double clicking center button to access "Options", Tap the <Up/Down> button to select "Temperature C/ F".
4. Double clicking center button to access "Temperature C/ F", The display will show "Fahrenheit", Tap the <Up/Down> button to select "Celsius".
5. Double click the center button to confirm or long press the center button to return to the main menu.

10.3.6. Initial Pos.

With this function you can display initial effect position.

1. Double clicking center button to access main menu.
2. Tap the <Up/Down> button until "Options" is displayed.
3. Double clicking center button to access "Options", Tap the <Up/Down> button to select "Initial Pos.".
4. Double clicking center button to access "Initial Pos.", The display will show "PAN=XXX".
5. Double click the center button to confirm or long press the center button to return to the main menu.

10.3.7. Wireless

From factory, this projector is prepared for wireless data transmission (W-DMX). If you wish to de-activate W-DMX control, you can select the function "De-activate WDMX" by turning the encoder. With the function "rest", you can log out the projector from the wireless sender.

1. Double clicking center button to access main menu.
2. Tap the <Up/Down> button until “Options” is displayed.
3. Double clicking center button to access “Options”, Tap the <Up/Down> button to select “Wireless”.
4. Double clicking center button to access “Wireless”, The display will show “Activate WDMX”, Tap the <Up/Down> button to select “Act&Data Out” , “Rest WDMX”.
5. Double click the center button to confirm or long press the center button to return to the main menu.

10.3.8. Dim Curve

1. Double clicking center button to access main menu.
2. Tap the <Up/Down> button until “Options” is displayed.
3. Double clicking center button to access “Options”, Tap the <Up/Down> button to select “Dim Curve”.
4. Double clicking center button to access “Dim Curve”, The display will show “Square Law”, Tap the <Up/Down> button to select “Linear”.
5. Double click the center button to confirm or long press the center button to return to the main menu.

10.3.9. Ip From Mac

1. Double clicking center button to access main menu.
2. Tap the <Up/Down> button until “Options” is displayed.
3. Double clicking center button to access “Options”, Tap the <Up/Down> button to select “Ip From Mac”.
4. Double clicking center button to access “Ip From Mac”, The display will show “OFF”, Tap the <Up/Down> button to select “ON”.
5. Double click the center button to confirm or long press the center button to return to the main menu.

10.3.10. Refresh Select

With this function you can select the refresh.

1. Double clicking center button to access main menu.
2. Tap the <Up/Down> button until “Options” is displayed.
3. Double clicking center button to access “Options”, Tap the <Up/Down> button to select “Refresh Select”.
4. Double clicking center button to access “Refresh Select”, The display will show “1.2K”, Tap the <Up/Down> button to select “2.4K”, “16K”, “25K”.
5. Double click the center button to confirm or long press the center button to return to the main menu.

10.3.11. Defog

1. Double clicking center button to access main menu.
2. Tap the <Up/Down> button until “Options” is displayed.
3. Double clicking center button to access “Options”, Tap the <Up/Down> button to select “Defog”.
4. Double clicking center button to access “Defog”, The display will show “OFF”, Tap the <Up/Down> button to select “ON”.
5. Double click the center button to confirm or long press the center button to return to the main menu.

10.3.12. Trigger

DMX Value Disp.

With this function you can display the DMX 512 value of each channel. The display automatically shows the channel with a value changing.

1. Double clicking center button to access main menu.
2. Tap the <Up/Down> button until “Options” is displayed.
3. Double clicking center button to access “Options”, Tap the <Up/Down> button to select “Trigger”.
4. Double clicking center button to access “Trigger” menu, Tap the <Up/Down> button to select “DMX Value Disp”.
5. Double clicking center button to access “DMX Value Disp”, The display will show “PAN=.....”.
6. Double click the center button to confirm or long press the center button to return to the main menu.

Set To Slave

With this function, you can define the device as slave.

1. Double clicking center button to access main menu.
2. Tap the <Up/Down> button until “Options” is displayed.
3. Double clicking center button to access “Options”, Tap the <Up/Down> button to select “Trigger”.
4. Double clicking center button to access “Trigger” menu, Tap the <Up/Down> button to select “Set To Slave”.
5. Double clicking center button to access “Set To Slave”, The display will show “Slave1”, “Slave2”, “Slave3”.
6. Double click the center button to confirm or long press the center button to return to the main menu.

Auto Program

With this function, you can run the internal program. You can select the desired program under “**Select program**”. You can set the number of steps under “**Edit program**”. You can edit the individual scenes under “**Edit scenes**”. With this function, you can run the individual scenes either automatically, i.e. with the adjusted Step-Time.

1. Double clicking center button to access main menu.
2. Tap the <Up/Down> button until “Options” is displayed.
3. Double clicking center button to access “Options”, Tap the <Up/Down> button to select “Trigger”.
4. Double clicking center button to access “Trigger” menu, Tap the <Up/Down> button to select “Auto Program”.
5. Double clicking center button to access “Auto Program”, The display will show “Master”, “Alone”.
6. Double click the center button to confirm or long press the center button to return to the main menu.

10.3.13. Reset Default

With this function, you can select restore factory set for ON or OFF, the default is OFF.

1. Double clicking center button to access main menu.
2. Tap the <Up/Down> button until “Options” is displayed.
3. Double clicking center button to access “Options”, Tap the <Up/Down> button to select “Reset Default”.
4. Double clicking center button to access “Reset Default” menu, The display will show “OFF”, Tap the <Up/Down> button to select “ON”.
5. Double click the center button to confirm or long press the center button to return to the main menu.

10.3.14. Reset User Address

1. Double clicking center button to access main menu.
2. Tap the <Up/Down> button until “Options” is displayed.
3. Double clicking center button to access “Options”, Tap the <Up/Down> button to select “Reset User”.
4. Double clicking center button to access “Reset User” menu, Tap the <Up/Down> button to select “Address”.
5. Double clicking center button to access “Address”, The display will show “001~XXX”.
6. Double click the center button to confirm or long press the center button to return to the main menu.

Mode

1. Double clicking center button to access main menu.
2. Tap the <Up/Down> button until “Options” is displayed.
3. Double clicking center button to access “Options”, Tap the <Up/Down> button to select “Reset User”.
4. Double clicking center button to access “Reset User” menu, Tap the <Up/Down> button to select “Mode”.
5. Double clicking center button to access “Mode”, The display will show “Extend Mode”. Tap the <Up/Down> button to select “Basic mode”, “Stand Mode”, “User Mode A”, “User Mode B” and “User Mode C”.
6. Double click the center button to confirm or long press the center button to return to the main menu.

Fans Speed

1. Double clicking center button to access main menu.
2. Tap the <Up/Down> button until “Options” is displayed.
3. Double clicking center button to access “Options”, Tap the <Up/Down> button to select “Reset User”.
4. Double clicking center button to access “Reset User” menu, Tap the <Up/Down> button to select “Fans Speed”.
5. Double clicking center button to access “Fans Speed”, The display will show “Auto”. Tap the <Up/Down> button to select “Stage”, “Silence”, “Super Silence”.
6. Double click the center button to confirm or long press the center button to return to the main menu.

Constant Fans

1. Double clicking center button to access main menu.
2. Tap the <Up/Down> button until “Options” is displayed.
3. Double clicking center button to access “Options”, Tap the <Up/Down> button to select “Reset User”.
4. Double clicking center button to access “Reset User” menu, Tap the <Up/Down> button to select “Constant Fans”.
5. Double clicking center button to access “Constant Fans”, The display will show “OFF”. Tap the <Up/Down> button to select “ON”.
6. Double click the center button to confirm or long press the center button to return to the main menu.

10.4. Info

10.4.1. Time Info.

Current Time

With this function, you can display the temporary running time of the device from the last power on. The display shows “XXXX”, “XXXX” stands for the number of hours. The

counter is reset after turning the device off.

1. Double clicking center button to access main menu.
2. Tap the <Up/Down> button until "Info" is displayed.
3. Double clicking center button to access "Info", Tap the <Up/Down> button to select "Time Info."
4. Double clicking center button to access "Time Info.", Tap the <Up/Down> button to select "Current Time".
5. Double clicking center button to access "Current Time", The display will show "XXXX (Hours)".
6. Double click the center button to confirm or long press the center button to return to the main menu.

Ttl Life Hrs

With this function, you can display the running time of the device. The display shows "XXXX", "XXXX" stands for the number of hours.

1. Double clicking center button to access main menu.
2. Tap the <Up/Down> button until "Info" is displayed.
3. Double clicking center button to access "Info", Tap the <Up/Down> button to select "Time Info."
4. Double clicking center button to access "Time Info.", Tap the <Up/Down> button to select "Ttl Life Hrs".
5. Double clicking center button to access "Ttl Life Hrs", The display will show "XXXX (Hours)".
6. Double click the center button to confirm or long press the center button to return to the main menu.

Last Run Hrs

With this function, you can display last the running time of the device. The display shows "XXXX", "XXXX" stands for the number of hours.

1. Double clicking center button to access main menu.
2. Tap the <Up/Down> button until "Info" is displayed.
3. Double clicking center button to access "Info", Tap the <Up/Down> button to select "Time Info."
4. Double clicking center button to access "Time Info.", Tap the <Up/Down> button to select "Last Run Hrs".
5. Double clicking center button to access "Last Run Hrs", The display will show "XXXX (Hours)".
6. Double click the center button to confirm or long press the center button to return to the main menu.

LED Hours

With this function, you can display the time of LED. The display shows "XXXX", "XXXX" stands for the time of LED.

1. Double clicking center button to access main menu.
2. Tap the <Up/Down> button until "Info" is displayed.
3. Double clicking center button to access "Info", Tap the <Up/Down> button to select "Time Info."
4. Double clicking center button to access "Time Info.", Tap the <Up/Down> button to select "LED Hours".
5. Double clicking center button to access "LED Hours", The display will show "XXXX (Hours)".
6. Double click the center button to confirm or long press the center button to return to the main menu.

Timer PIN

With this function, you can display the timer password.

1. Double clicking center button to access main menu.
2. Tap the <Up/Down> button until "Info" is displayed.
3. Double clicking center button to access "Info", Tap the <Up/Down> button to select "Time Info."
4. Double clicking center button to access "Time Info.", Tap the <Up/Down> button to select "Timer PIN".
5. Double clicking center button to access "Timer PIN", The display will show "Password=038".
6. Double click the center button to confirm or long press the center button to return to the main menu.

Clr Last Run

With this function, you can clear last run time of the fixture. The display shows "ON" or "OFF".

1. Double clicking center button to access main menu.
2. Tap the <Up/Down> button until "Info" is displayed.
3. Double clicking center button to access "Info", Tap the <Up/Down> button to select "Time Info."
4. Double clicking center button to access "Time Info.", Tap the <Up/Down> button to select "Clear Last Run".
5. Double clicking center button to access "Clear Last Run", The display will show "OFF", Tap the <Up/Down> button to select "ON".
6. Double click the center button to confirm or long press the center button to return to the main menu.

10.4.2. Temp.Info

With this function you can display the temperature on the display board of the base (near CMY-filter) in Celsius.

1. Double clicking center button to access main menu.
2. Tap the <Up/Down> button until "Info" is displayed.
3. Double clicking center button to access "Info", Tap the <Up/Down> button to select "Temp Info".
4. Double clicking center button to access "Time Info.", The display will show "XXX °C/ °F".
5. Double click the center button to confirm or long press the center button to return to the main menu.

10.4.3. Humidity

1. Double clicking center button to access main menu.
2. Tap the <Up/Down> button until "Info" is displayed.
3. Double clicking center button to access "Info", Tap the <Up/Down> button to select "Humidity".
4. Double clicking center button to access "Humidity", The display will show "x%".
5. Double click the center button to confirm or long press the center button to return to the main menu.

10.4.4. Fan Info.

With this function, you can display the software version of the device.

1. Double clicking center button to access main menu.
2. Tap the <Up/Down> button until "Info" is displayed.
3. Double clicking center button to access "Info", Tap the <Up/Down> button to select

“Fan Info.”.

4. Double clicking center button to access “Fan Info.”, The display will show “xxxxRPM”.
5. Double click the center button to confirm or long press the center button to return to the main menu.

10.4.5. Software Ver

With this function, you can display the software version of the device.

1. Double clicking center button to access main menu.
2. Tap the <Up/Down> button until “Info” is displayed.
3. Double clicking center button to access “Info”, Tap the <Up/Down> button to select “Software Ver”.
4. Double clicking center button to access “Software Ver”, The display will show “Ver x.x.x”.
5. Double click the center button to confirm or long press the center button to return to the main menu.

10.4.6. Network

1. Double clicking center button to access main menu.
2. Tap the <Up/Down> button until “Info” is displayed.
3. Double clicking center button to access “Info”, Tap the <Up/Down> button to select “Network”.
4. Double clicking center button to access “Network”, The display will show “IP” , Turn the center button to select “Mask”, “Mac”.
5. Double click the center button to confirm or long press the center button to return to the main menu.

10.4.7. Error Info

1. Double clicking center button to access main menu.
2. Tap the <Up/Down> button until “Info” is displayed.
3. Double clicking center button to access “Info”, Tap the <Up/Down> button to select “Error Info”.
4. Double clicking center button to access “Error Info”, The display will show “Error Record 1” , “.....”, “Error Record 10”.
5. Double click the center button to confirm or long press the center button to return to the main menu.

10.4.8. SN

1. Double clicking center button to access main menu.
2. Tap the <Up/Down> button until “Info” is displayed.
3. Double clicking center button to access “Info”, Tap the <Up/Down> button to select “SN”.
4. Double clicking center button to access “SN”, The display will show “xxxxx” , “.....”.
5. Double click the center button to confirm or long press the center button to return to the main menu.

10.5. Test

10.5.1. Home

With this function you can reset the device via the Control Board. You can select the different reset functions by turning the encoder.

1. Double clicking center button to access main menu.
2. Tap the <Up/Down> button until “Test” is displayed.
3. Double clicking center button to access “Test”, Tap the <Up/Down> button to select “Home”.

4. Double clicking center button to access “Home”, The display will show “All” , Tap the <Up/Down> button to select “All”, “Pan&Tilt”, “ZOOM”.
5. Double click the center button to confirm or long press the center button to return to the main menu.

10.5.2. Test Channel

With this function you can test each channel’s function to ensure correct operation.

1. Double clicking center button to access main menu.
2. Tap the <Up/Down> button until “Test” is displayed.
3. Double clicking center button to access “Test”, Tap the <Up/Down> button to select “Test Channel”.
4. Double clicking center button to access “Test Channel”, The display will show “Pan”, Tap the <Up/Down> button to select other channel.
5. Double click the center button to confirm or long press the center button to return to the main menu.

10.5.3. Manual Control

When set to Manual Mode, fixture will be back to factory settings. If want to adjust brightness, can adjust by shutter and dimming channel, channel value is 0-255. Other functions can be set according to user’s real need.

1. Double clicking center button to access main menu.
2. Tap the <Up/Down> button until “Test” is displayed.
3. Double clicking center button to access “Test”, Tap the <Up/Down> button to select “Manual control”.
4. Double clicking center button to access “Manual control”, The display will show “PAN=XXX”.
5. Double click the center button to confirm or long press the center button to return to the main menu.

10.5.4. Calibration

With this function, you can calibrate and adjust the effect wheels to their correct positions. The password of calibrate values is 050.

1. Double clicking center button to access main menu.
2. Tap the <Up/Down> button until “Test” is displayed.
3. Double clicking center button to access “Test”, Tap the <Up/Down> button to select “Calibration”.
4. Double clicking center button to access “Calibration”, The display will show “Password=050”.
5. Double click the center button to confirm or long press the center button to return to the main menu.

10.6. Preset

1. Double clicking center button to access main menu.
2. Tap the <Up/Down> button until “Preset” is displayed.
3. Double clicking center button to access “Preset”, Tap the <Up/Down> button to select “Select prog.”, “Edit prog.”, “Edit Scenes”, “Scenes Input”.
4. Double click the center button to confirm or long press the center button to return to the main menu.

Run the auto program: A master fixture can output to three different program signals to the slave fixture to operate. It means the host will send cyclically in the following orders (The host will keep operating the program of Part 1) Then the slave fixture will make the selectively receiving according to its own set.

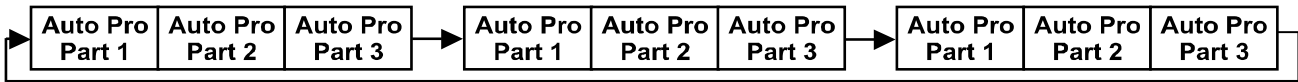

1. If the slave fixture chooses Run For Slave 1 from the menu of 1-3, then it will receive the part 1's automatic program from link, in the same way, when the slave fixture chooses Run For Slave 2, then it will receive the part 2's automatic program from link.
2. Enter the menu of 1-3 Function Mode---Set To Slave, Here to set machine operate which part of the program during the host-slave connection
3. Enter the menu of 1-4, 1-5 Function Mode---Set To Master
4. Enter the menu of 8-1 Edit Program---Auto Program Part1. The host outputs three groups driven program---Part1, Part2, Part3 (Part1 program runs the same effect as the host)
5. Enter the menu of 8-2 Edit Program---Edit Program. Edit the program's connection, connect the scene in order
6. The editor of the scene, there are as many as 250 scenario editors, and every scene can have a program connection of 10.

Note:

Part 2, Part 3 repeat in accordance with the Part 1's repeat. For example: When Part 1 uses Program 2, Part 2 uses Program 4, Part 3 uses Program 6, Assume: Program 2 includes scene of 10, 11, 12, 13; Program 4 includes scene of 8, 9, 10; Program 6 includes scene of 12, 13, 14, 15; Then it will run as below.

Example:

Part 1:

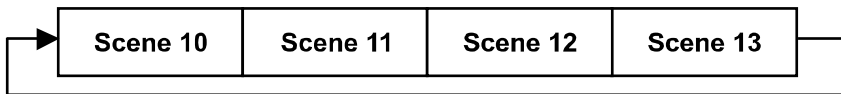

Part 2:

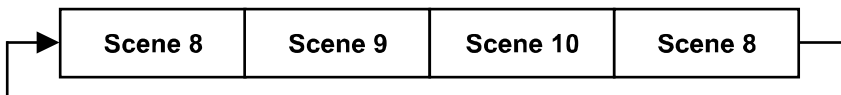

Part 3:

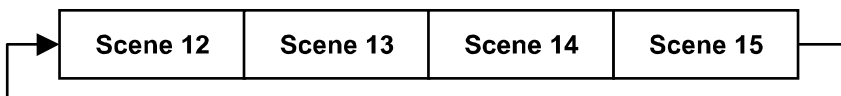

11. NFC

When the fixture is powered on, you can use the Ayrton NFC App to scan the NFC tag area of the fixture to read some of the information or settings inside the display menu, such as product name, software version, UID, DMX Start Address, Universe, User Mode, Options, Information, etc. You can also change some of the settings and push to write inside the fixture menu.

When the fixture is not powered on, you can still use the App to read the NFC info and write the settings into the NFC tag, the written data will be automatically synchronized into the fixture menu at next time the fixture is powered on.

(Note: the NFC tag is right under the LCD window)

11.1 How to use NFC

First install Ayrton NFC App into your mobile phone and enable NFC function of your mobile.

1) Open the Ayrton NFC App (as shown in Figure 1), tap the button to activate NFC scan (Figure 2), place the NFC scan area of your mobile phone close to the NFC tag area of the fixture, it will show the setting and configuration page after reading successfully (Figure 3).

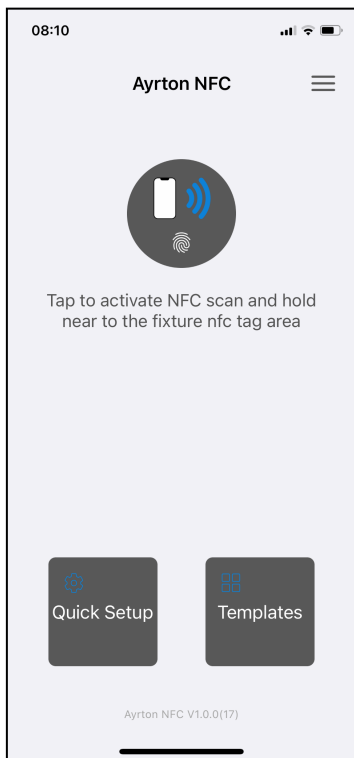

Figure 1

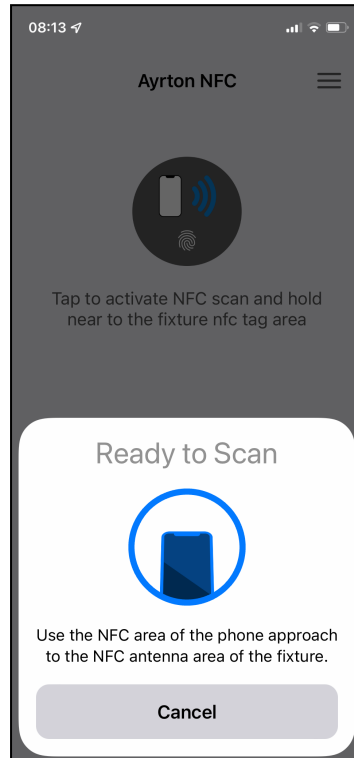

Figure 2

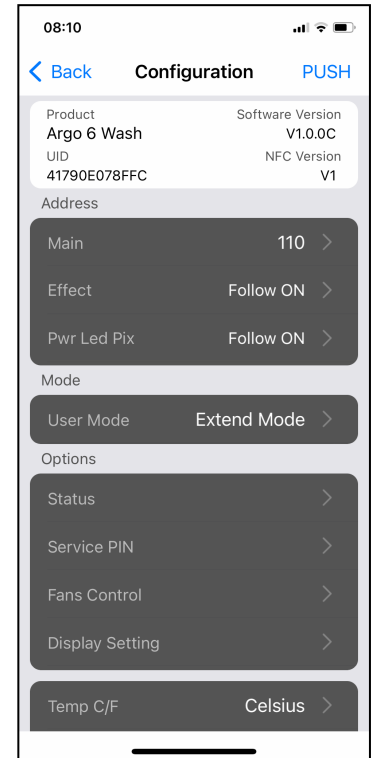

Figure 3

2) Change the device parameters such DMX address or User Mode or others (Figure 4, 5):

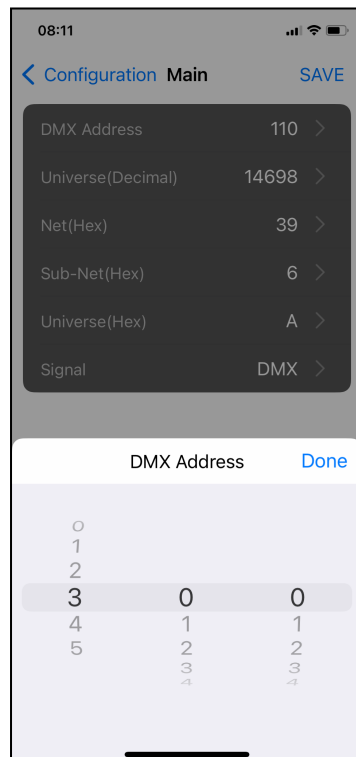

Figure 4

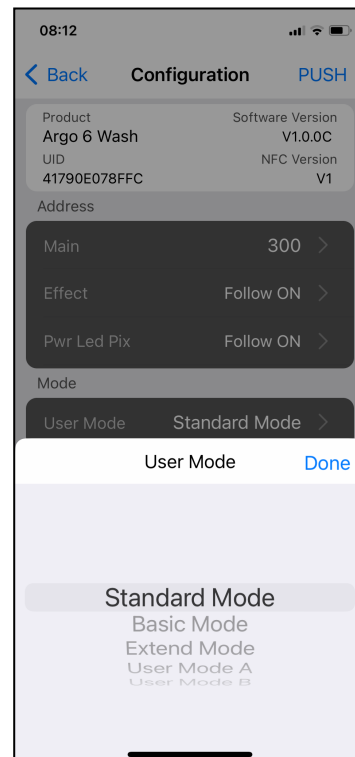

Figure 5

3) Tap 'PUSH' on the upper right corner (Figure 6, 7) and place the NFC scan area of your mobile phone close to the NFC tag area of the fixture to write into the NFC tag (Figure 8).

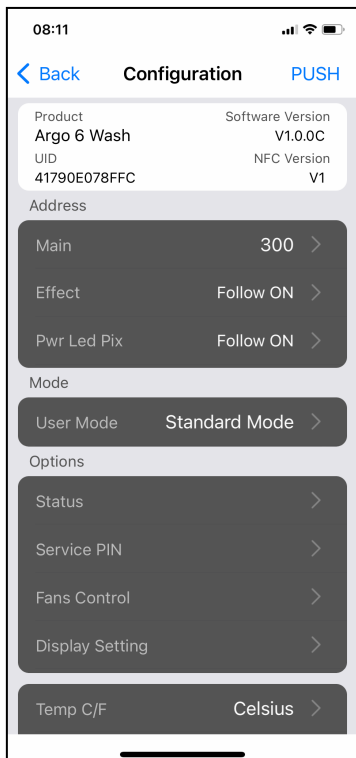

Figure 6

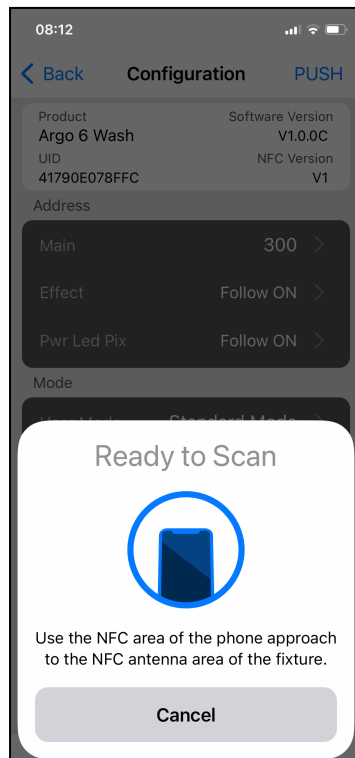

Figure 7

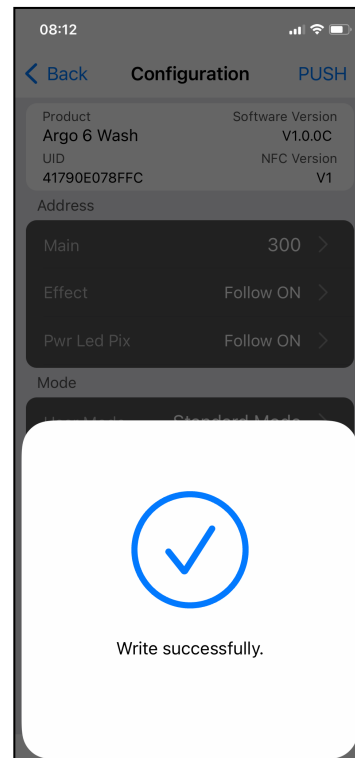

Figure 8

4) Quick Setup menu:

In the home page, tap the “Quick Setup” button to show the quick setup parameters and tap the upper right corner button to view the quick setting options (Figure 9): “PUSH” to write the NFC settings (Figure 10), “EDIT” to add or delete the setting menus into the “Quick Setup” list (Figure 11).

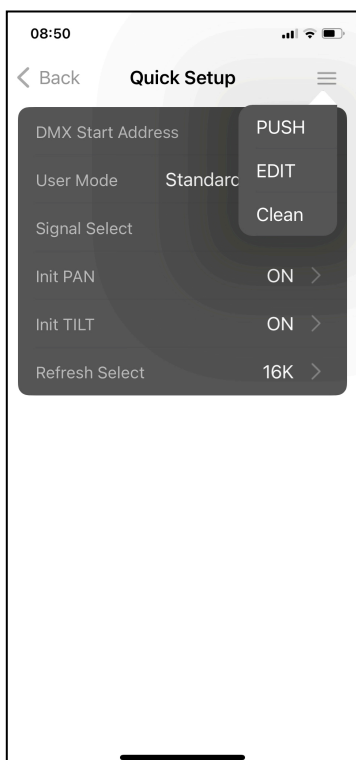

Figure 9

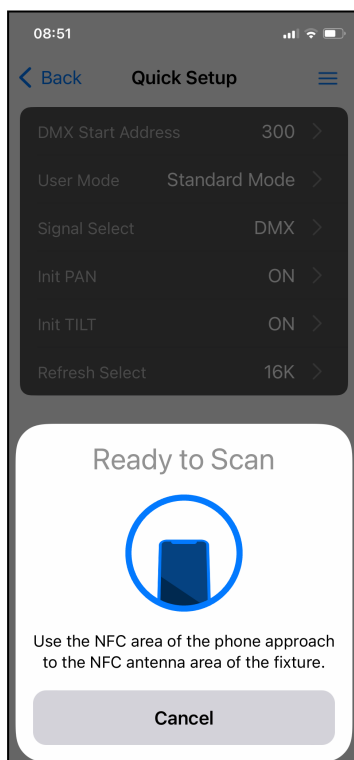

Figure 10

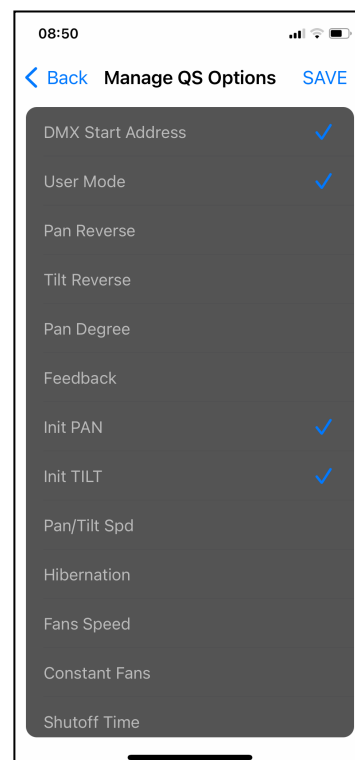

Figure 11

5) Templates menu

Create a fixture parameter template and set it to the corresponding fixture model

Tap to enter the Templates list page (Figure 12), tap the upper right corner to add a new template for your fixture model (Figure 13), change the Template name and parameter settings and tap "ADD" to add into the Template list, as shown in Figure 14

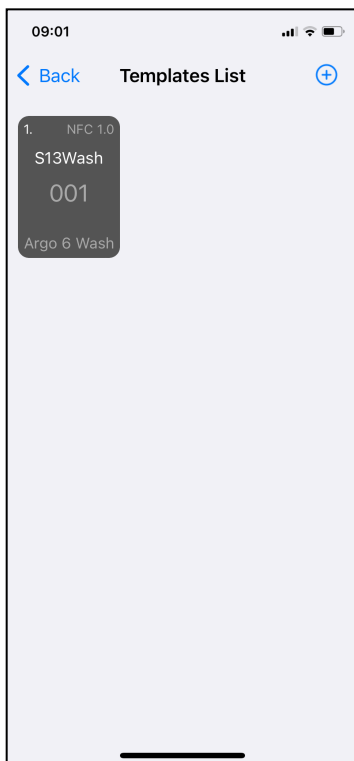

Figure 12

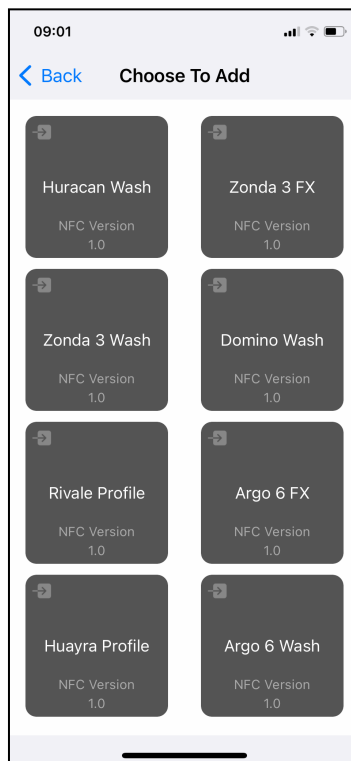

Figure 13

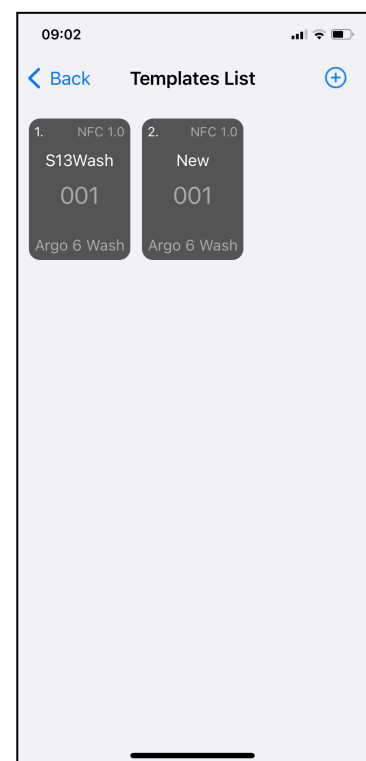

Figure 14

Pressing the desired template to activate the options (Figure 15), tap "PUSH" to write into the NFC tag of the fixture, as shown in Figure 16.

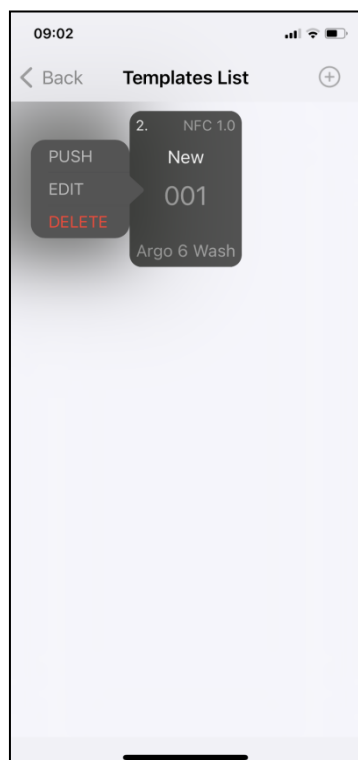

Figure 15

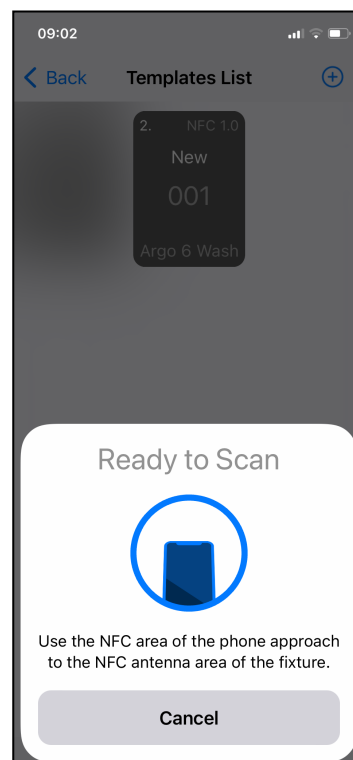

Figure 16

12. DMX PROTOCOL

DMX channel's functions and their values (127DMX channels):				
Mode/Channel			Value	Function
BASIC	STAND	EXTEND		
1	1	1		<u>PAN Movement 8bit:</u>
			0-255	Pan Movement
2	2	2		<u>Pan Fine 16bit:</u>
			0-255	Fine control of Pan movement
3	3	3		<u>TILT Movement 8bit :</u>
			0-255	Tilt Movement
4	4	4		<u>Tilt Fine 16bit:</u>
			0-255	Fine control of Tilt movement
5	5	5		<u>Speed Pan/Tilt movement:</u>
			0-225	max to min speed
			226-235	blackout by movement
			236-255	store dimmer enabled
6	6	6		<u>Pan Motor continuous rotation:</u>
			0-63	stop rotation by spinout
			64-127	stop rotation by shortcut
			128-189	Forwards Pan rotation from fast to slow
			190-193	No rotation
194-255	Backwards Pan rotation from slow to fast			
7	7	7		<u>Tilt Motor continuous rotation:</u>
			0-63	stop rotation by spinout
			64-127	stop rotation by shortcut
			128-189	Forwards Tilt rotation from fast to slow
			190-193	No rotation
194-255	Backwards Tilt rotation from slow to fast			
8	8	8		<u>Red LED -all arrays / Background color when Chase ON :</u>
			0-255	Red (0-Black , 255-100% Red)
9	9	9		<u>Red fine LED -all arrays / Background color when Chase ON :</u>
			0-255	Red fine (0-Black , 255-100% Red)
10	10	10		<u>Green LED-all arrays / Background color when Chase ON :</u>
			0-255	Green (0-Black , 255-100% Green)
11	11	11		<u>Green fine LED-all arrays / Background color when Chase ON:</u>
			0-255	Green fine (0-Black , 255-100% Green)

12	12	12		<u>Blue LED -all arrays / Background color when Chase ON:</u>
			0-255	Blue (0-Black , 255-100% Blue)
13	13	13		<u>Blue fine LED -all arrays / Background color when Chase ON:</u>
			0-255	Blue fine (0-Black , 255-100% Blue)
14	14	14		<u>White LED -all arrays / Background color when Chase ON:</u>
			0-255	White (0-Black , 255-100% White)
15	15	15		<u>White fine LED -all arrays / Background color when Chase ON:</u>
			0-255	White fine (0-Black , 255-100% White)
16	16	16		<u>Shutter, strobe:</u>
			0-31	Led turn off
			32-63	Led turn on
			64-95	Strobe effect slow to fast
			96-127	Led turn on
			128-159	Pulse-effect in sequences
			160-191	Led turn on
			192-223	Random strobe effect slow to fast
224-255	Led turn on			
17	17	17		<u>Dimmer intensity:</u>
			0-255	Intensity 0 to 100%
18	18	18		<u>Dimmer fine intensity:</u>
			0-255	Intensity fine 0 to 100%
19	19	19		<u>Linear CTO from 8000 to 2500K:</u>
			0-21	No function
			22-42	8000K-7500k
			43-63	7500K-7000k
			64-84	7000K-6500k
			85-105	6500K-6000k
			106-126	6000K-5500k
			127-147	5500K-5000k
			148-168	5000K-4500k
			169-189	4500K-4000k
			190-210	4000K-3500k
			211-231	3500K-3000k
232-255	3000k-2500k			
20	20	20		<u>Color preset:</u>
			0-205	See Appendix
21	21	21		<u>Color Preset / RGBW cross fade:</u>

			0	Output controlled by RGBW values
			1-254	Cross fade between RGBW settings and Color preset channel
			255	Output controlled by color preset values
22	22	22		<u>Between Color Preset cross fade:</u>
			0-4	no fade
			4-255	Cross fade between 2 color presets from 100ms to 5sec
23	23	23		<u>Zoom :</u>
			0-255	Zoom adjustment
24	24	24		<u>Zoom Fine :</u>
			0-255	Fine control for Zoom adjustment
25	25	25		<u>Reserved channel:</u>
			0-255	Reserved
26	26	26		<u>Reset, internal programs:</u>
			0-4	unused
			5-9	Display Off
			10-14	Display On
			15-19	Display Invert Off
			20-24	Display Invert On
			25-26	Auto fan control mode
			27-28	Stage fan control mode
			29-30	Silence fan control mode
			31-32	Super Silence fan control mode
			33-34	Constant Fans Off
			35-36	Constant Fans On
			37-44	unused
			45-49	Square Law
			50-54	Linear
			55-57	1.2K
			58-60	2.4K
			61-63	16K
			64-69	25K
			70-71	Tungsten lamp simulation 500W
			72-73	Tungsten lamp simulation 1000W
			74-75	Tungsten lamp simulation 2500W
			76-77	Tungsten lamp simulation 5000W
			78-79	Tungsten lamp simulation off
			80-84	All motor reset
			85-87	P/T motor reset

			88-90	Zoom motor reset
			91-93	Edit a new dimmer
			94-96	Store a new dimmer
			97-99	Recover dimmer
			100-102	IP from mac off
			103-105	IP from mac on
			106-108	fog fan off
			109-111	fog fan auto
			112-114	fog fan on
			115-255	Reserved
				<u>Main LED Chase Patterns:</u>
			0--9	Chase OFF
			10-14	Chase 1
			15-19	Chase 2
			20-24	Chase 3
			25-29	Chase 4
			30-34	Chase 5
			35-39	Chase 6
			40-44	fix Chase
			45-255	Reserved
				<u>Main LED Chase Speed:</u>
			0-125	Fast to Slow Backward
			126-130	Stop(Speed=0)
			131-255	Slow to Fast Forward
				<u>Main LED Chase Fade:</u>
			0-255	Fade Chase
				<u>Main LED Chase Size:</u>
			0-255	chase category
				<u>Red Chase color:</u>
			0-255	Red (0-Black , 255-100% Red)
				<u>Green Chase color:</u>
			0-255	Green (0-Black , 255-100% Green)
				<u>Blue Chase color:</u>
			0-255	Blue (0-Black , 255-100% Blue)
				<u>White Chase color:</u>
			0-255	Blue (0-Black , 255-100% White)
				<u>Dimmer Chase:</u>
			0-255	Intensity (0-Black , 255-100%)
				<u>Dimmer background Chase: inverted disabled</u>
	27	27		
	28	28		
	29	29		
	30	30		
	31	31		
	32	32		
	33	33		
	34	34		
	35	35		
	36	36		

			0-255	Intensity 0 to 100%
	48	48		<u>Liquid background effect Red color:</u>
			0-255	Red (0-Black , 255-100% Red)
	49	49		<u>Liquid background Effect Green color:</u>
			0-255	Green (0-Black , 255-100% Green)
	50	50		<u>Liquid background Effect Blue color:</u>
			0-255	Blue (0-Black , 255-100% Blue)
		51		<u>Cross fade to PIXEL mode:</u>
			0-255	from RGBW control to PIXEL control
		52		<u>Red LED -array 1 :</u>
			0-255	Red (0-Black , 255-100% Red)
		53		<u>Green LED-array 1 :</u>
			0-255	Green (0-Black , 255-100% Green)
		54		<u>Blue LED -array 1 :</u>
			0-255	Blue (0-Black , 255-100% Blue)
		55		<u>White LED -array 1 :</u>
			0-255	White (0-Black , 255-100% White)
		56		<u>Red LED -array 2 :</u>
			0-255	Red (0-Black , 255-100% Red)
		57		<u>Green LED-array 2 :</u>
			0-255	Green (0-Black , 255-100% Green)
		58		<u>Blue LED -array 2 :</u>
			0-255	Blue (0-Black , 255-100% Blue)
		59		<u>White LED -array 2 :</u>
			0-255	White (0-Black , 255-100% White)
	
		124		<u>Red LED -array 19 :</u>
			0-255	Red (0-Black , 255-100% Red)
		125		<u>Green LED-array 19 :</u>
			0-255	Green (0-Black , 255-100% Green)
		126		<u>Blue LED -array 19 :</u>
			0-255	Blue (0-Black , 255-100% Blue)
		127		<u>White LED -array 19:</u>
			0-255	White (0-Black , 255-100% White)

13. ERROR MESSAGES

When you turn on the device, it will first perform a reset. The display may show “Err channel is

“XX” should there be problems with one or more functions. “XX” stands for channel 1, 2, 3, 4, 5, 6 etc whose sensor has encountered a problem. For example, when the display shows “Err channel is Pan movement”, it means there is an error on channel 1. If there are errors on channel 1, channel 3, channel 12 at the same time, you may see the error message, “Err channel is Pan movement”, “Err channel is Tilt movement” “Err channel is Shutter”, flash twice, and then the device will generate a second reset. If the error messages persist after performing a reset more than twice, the channels which have errors may not work properly however, all other functions can work as usual. Please contact your dealer or manufacturer for service. Self repair is not allowed.

PAN- movement Er

(PAN- movement error) This message will appear after the reset of the fixture if the yoke’s magnetic-indexing circuit malfunction (Optical Sensor or Magnetic Sensor fails) or the stepper motor is defective (or its driving IC on the main PCB). The PAN- movement is not located in the default position after the reset.





TILT- movement Er

(TILT- movement error) This message will appear after the reset of the fixture if the head’s magnetic-indexing circuit malfunctions ((Optical Sensor or Magnetic Sensor fails)) or the stepper motor is defective (or its driving IC on the main PCB). The TILT- movement is not located in the default position after the reset.

Zoom wheel Er

(Zoom wheel error) This message will appear after the reset of the fixture if the head’s magnetic-indexing circuit malfunctions (Optical Sensor or Magnetic Sensor fails) or the stepper motor is defective (or its driving IC on the main PCB). The Zoom - movement is not located in the default position after the reset.

14. CLEANING AND MAINTENANCE

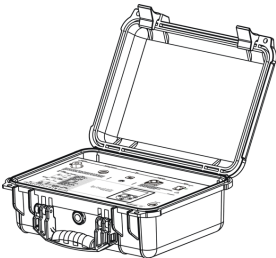
	<p align="center">CAUTION!</p> <p>DISCONNECT FROM MAINS BEFORE STARTING MAINTENANCE OPERATION.</p>	
	<p align="center">WARNING!</p> <p>DO NOT PLACE THE FIXTURE WITH ITS LENS/GLASS FACING ANY PEOPLE WHILE DOING THE IP TEST!</p>	
	<p align="center">CAUTION!</p> <p>NEVER USE ALCOHOL OR SOLVENT TO CLEAN THE LENSES !</p>	
	<p align="center">CAUTION!</p> <p>ALWAYS RUN AN IP TEST USING THE AYRTON IP TEST KIT FOLLOWING ANY MAINTENANCE OPERATION! FAILURE TO COMPLY WITH THIS CLAUSE WILL VOID THE WARRANTY!</p> <p>THE OPERATOR MUST FOLLOW STRICTLY THE VACUUM AND PRESSURE SETTING VALUES AS BELOW, OR USE THE CORRESPONDING PRESET FIXTURE MENU TO RUN THE IP TEST. ANY OVERPRESSURE OPERATION MAY CAUSE ACCIDENTAL DAMAGE OR INJURY.</p>	 <p align="center">AYRTON IP TEST KIT</p>

	Minimum value		Maximum value		Steady time (Hold time)
	Kpa	Psi	Kpa	Psi	
Vacuum	-13	-5.08	-17	5.80	10
Pressure	13	3.63	17	4.35	10

Once the covers removed and before set them back, check the cover gasket to avoid any leak due to gasket damage.

Cross tightening the die-casting covers HEX screws at the right torque value.

Use a Torque Screwdriver set at 1,4Nm (12,4in/lbf) to fasten correctly the (10) HEX head screws for each cover.

The following points have to be considered during inspection:

- 1) All screws for installing the devices or parts of the device have to be tightly connected and must not be corroded.
- 2) All external magnesium alloy covers screws must be used together with the plastic sleeves. If the plastic sleeve is damaged, it must be replaced with a new one.
- 3) Do not do maintenance or assembly for the external magnesium alloy cover in outdoor environment with rain or water on it. Before removing the screws, ensure that the surroundings of the screws are dry. After maintenance, before assembling the covers, ensure that the screws and screw holds are dry.
- 4) There must not be any deformations to the housing, lenses, rigging and installation points (ceiling, suspension, trussing).
- 5) Motorized parts must not show any signs of wear and must move smoothly without issue.
- 6) The power supply cables must not show any damage, material fatigue or sediment.

Checking and replacing the desiccant

The desiccant is used as humidity indication in the fixture. Dry desiccant is in blue color, if it is saturated with water, its color changes to light red. If the desiccant color changes to pink, the desiccant is losing efficacy, it must be replaced.

	<p>UNPUG THE FIXTURE FROM MAINS BEFORE CHECKING OR REPLACING DESICCANT!</p> <p>DO NOT CHECK OR REPLACE DESICCANT IN A DAMP ENVIRONMENT!</p>
---	---

Further instructions depending on the installation location and usage have to be adhered to by a qualified installer and any safety concerns have to be removed.

In order to ensure the device remains in good condition and does not fail prematurely, we suggest regular maintenance.

- 1) Clean the outside lens each week to avoid loss of output due to accumulation of dust/ dirt on the lens.
- 2) Clean the fans each week to ensure maximum airflow and efficient thermal cooling. This will ensure the light source is operated in the best possible condition.
- 3) A detailed electrical check by an approved electrician every quarter to make sure that the circuit contacts are in good condition. This will prevent poor circuit contacts and the resultant overheating.

We recommend frequent cleaning of the device. Please use a moist, lint- free cloth. Never use alcohol or solvents.

Please refer to the instructions under “Installation instructions”.

Should you need any spare parts, please order genuine parts from your local dealer.

*Errors and omissions for all information given in this user manual are expected.
All information is subject to change without prior notice.*

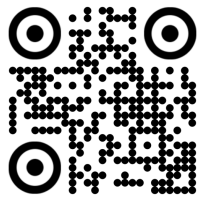

scan for more on
www.ayrton.eu



AYRTON
Digital Lighting

2 Rue de Vitruve - 91140 - Villebon-sur-Yvette - France